

Shield High Power Inductor SHP1280AP Series

DIMENSIONS / 外形寸法

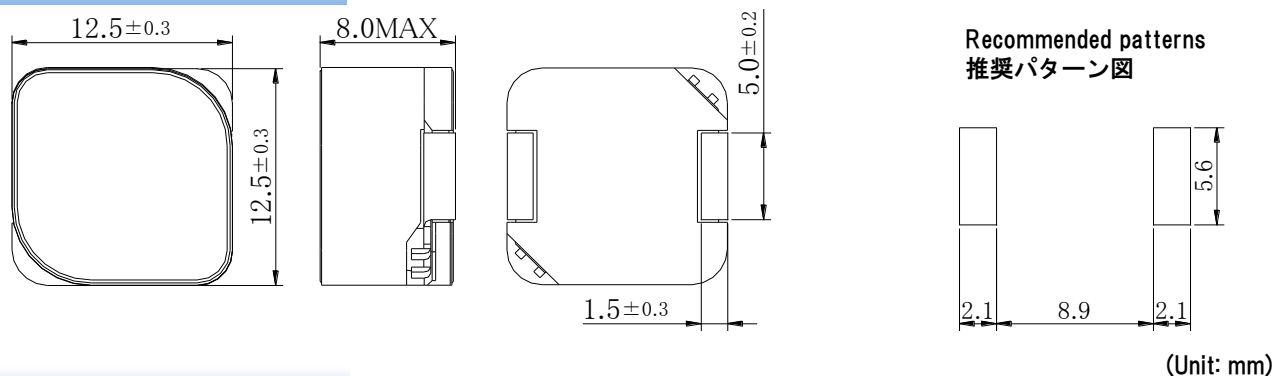

FEATURES / 特長

- Low leakage flux by complete closed magnetic circuit structure.
- Correspond to large saturation current by high Bm Ni-Zn ferrite core.
- 完全閉磁路構造により漏れ磁束が少ない
- 高B材Ni-Zn系フェライトコアによる高飽和電流対応

SPECIFICATIONS / 仕様

Parts No. 部品番号	Inductance *1 インダクタンス [μH]	Tolerance 許容差 [%]	DC Resistance *2 直流抵抗 [mΩ]	DC Resistance Max *2 最大直流 抵抗[mΩ]	DC Superimposition Current *3 直流重量 許容電流 [A]	Temperature Rise Current *4 温度上昇 許容電流 [A]
SHP1280P-F3R3AP	3.3	±30%	6	9	11.5	10.0
SHP1280P-F4R7AP	4.7	±30%	8	10	9.4	9.0
SHP1280P-F5R6AP	5.6	±30%	9	12	8.0	8.2
SHP1280P-F6R8AP	6.8	±30%	9	13	6.9	7.9
SHP1280P-F100AP	10	±20%	12	15	6.1	7.3
SHP1280P-F120AP	12	±20%	14	19	5.5	6.5
SHP1280P-F150AP	15	±20%	16	23	4.9	5.8
SHP1280P-F180AP	18	±20%	19	25	4.5	5.6
SHP1280P-F220AP	22	±20%	22	32	3.8	4.9
SHP1280P-F330AP	33	±20%	35	49	3.1	3.9
SHP1280P-F470AP	47	±20%	50	67	2.7	3.3
SHP1280P-F560AP	56	±20%	51	77	2.5	3.1
SHP1280P-F680AP	68	±20%	64	85	2.2	2.9
SHP1280P-F820AP	82	±20%	80	105	2.0	2.6
SHP1280P-F101AP	100	±20%	87	114	1.9	2.5
SHP1280P-F121AP	120	±20%	129	153	1.7	2.2
SHP1280P-F151AP	150	±20%	148	180	1.5	2.0
SHP1280P-F181AP	180	±20%	158	200	1.4	1.9
SHP1280P-F221AP	220	±20%	212	271	1.2	1.6
SHP1280P-F331AP	330	±20%	303	395	1.0	1.3
SHP1280P-F471AP	470	±20%	387	555	0.86	1.1

※This specification might be changed without notice due to under developing. Thank you for your understanding.
本仕様は開発中につき、製品の改善等により記載内容を予告無く変更することがありますので、ご了承下さい。

SPECIFICATIONS / 仕様

Parts No. 部品番号	Inductance *1 インダクタンス [μ H]	Tolerance 許容差 [%]	DC Resistance *2 直流抵抗 [m Ω]	DC Resistance Max *2 最大直流 抵抗[m Ω]	DC Superimposition Current *3 直流重量 許容電流 [A]	Temperature Rise Current *4 温度上昇 許容電流 [A]
SHP1280P-F561AP	560	$\pm 20\%$	463	600	0.79	1.05
SHP1280P-F681AP	680	$\pm 20\%$	537	650	0.72	1.00
SHP1280P-F821AP	820	$\pm 20\%$	717	840	0.65	0.89
SHP1280P-F102AP	1000	$\pm 20\%$	908	1020	0.59	0.83
SHP1280P-F152AP	1500	$\pm 20\%$	1300	1510	0.48	0.67
SHP1280P-F222AP	2200	$\pm 20\%$	1741	1930	0.40	0.57
SHP1280P-F332AP	3300	$\pm 20\%$	2308	2800	0.33	0.47
SHP1280P-F472AP	4700	$\pm 20\%$	3820	4250	0.27	0.38
SHP1280P-F682AP	6800	$\pm 20\%$	5200	6290	0.23	0.32
SHP1280P-F103AP	10000	$\pm 20\%$	7860	8860	0.18	0.26

*1 Inductance of F3R3AP~F821AP is measured at 100kHz .

Inductance of F102AP~F103AP is measured at 1kHz .

*2 DC Resistance is measured at ambient temperature 20°C.

*3 DC Current based upon 30% inductance reduction from the initial value.

*4 DC Current based upon 35°C temperature rise.

*5 Operating temperature is -40~125°C(includes coil heating).

F3R3AP~F821APインダクタンス測定、100kHz.

F102AP~F103APインダクタンス測定、1kHz.

直流抵抗は周囲温度20°Cにおいて測定.

インダクタンスが初期値より-30%になる直流電流値.

温度上昇 $\Delta T=35^\circ\text{C}$ になる直流電流値.

動作温度、-40~125°C(コイルの発熱を含む) .

※This specification might be changed without notice due to under developing. Thank you for your understanding.

本仕様は開発中につき、製品の改善等により記載内容を予告無く変更することがありますので、ご了承下さい。